

The Economic Viability of Mars Colonization

Robert Zubrin
Lockheed Martin Astronautics
PO Box 179
Denver, CO 80201, USA

Abstract

The economic viability of colonizing Mars is examined. It is shown, that of all bodies in the solar system other than Earth, Mars is unique in that it has the resources required to support a population of sufficient size to create locally a new branch of human civilization. It is also shown that while Mars may lack any cash material directly exportable to Earth, Mars' orbital elements and other physical parameters gives a unique positional advantage that will allow it to act as a keystone supporting extractive activities in the asteroid belt and elsewhere in the solar system. The potential of relatively near-term types of interplanetary transportation systems is examined, and it is shown that with very modest advances on a historical scale, systems can be put in place that will allow individuals and families to emigrate to Mars at their own discretion. Their motives for doing so will parallel in many ways the historical motives for Europeans and others to come to America, including higher pay rates in a labor-short economy, escape from tradition and oppression, as well as freedom to exercise their drive to create in an untamed and undefined world. Under conditions of such large scale immigration, sale of real-estate will add a significant source of income to the planet's economy. Potential increases in real-estate values after terraforming will provide a sufficient financial incentive to do so. In analogy to frontier America, social conditions on Mars will make it a pressure cooker for invention. These inventions, licensed on Earth, will raise both Terrestrial and Martian living standards and contribute large amounts of income to support the development of the colony.

Introduction

A frequent objection raised against scenarios for the human settlement and terraforming of Mars is that while such projects may be technologically feasible, there is no possible way that they can be paid for. On the surface, the arguments given supporting this position appear to many to be cogent, in that Mars is distant, difficult to access, possesses a hostile environment and has no apparent resources of economic value to export. These arguments appear to be ironclad, yet it must be pointed out that they were also presented in the past as convincing reasons for the utter impracticality of the European settlement of North America and Australia. It is certainly true that the technological and economic problems facing Mars colonization in the 21st century are vastly different in detail than those that had to be overcome in the colonization of the New World in the 17th century, or Australia in the 19th century. Nevertheless, it is my contention that the argument against the feasibility of Mars colonization is flawed by essentially the same false logic and lack of understanding of real economics that resulted in repeated absurd misvaluations of the value of colonial settlements (as opposed to trading posts, plantations, and other extractive activities) on the part of numerous European government ministries during the 400 years following Columbus.

During the period of their global ascendancy, the Spanish ignored North America; to them it was nothing but a vast amount of worthless wilderness. In 1781, while Cornwallis was being blockaded into submission at Yorktown, the British deployed their fleet into the Caribbean to seize a few high-income sugar plantation islands from the French. In 1802, Napoleon Bonaparte sold a third of what is now the United States for 2 million dollars. In 1867 the Czar sold off Alaska for a similar pittance. The existence of Australia was known to Europe for two hundred years before the first colony arrived, and no European power

even bothered to claim the continent until 1830. These pieces of short-sighted statecraft, almost incomprehensible in their stupidity, are legendary today. Yet their consistency shows a persistent blind spot among policy making groups as to the true sources of wealth and power. I believe that it is certain that two hundred years from now, the current apathy of governments towards the value of extraterrestrial bodies, and Mars in particular, will be viewed in a similar light.

While I shall return to historical analogies periodically in this paper, the arguments presented here shall not be primarily historical in nature. Rather, they shall be based on the concrete case of Mars itself, its unique characteristics, resources, technological requirements, and its relationships to the other important bodies within our solar system.

Phases of Mars Colonization

In order to understand the economics of Mars colonization it is necessary first to examine briefly the different phases of activity that will be necessary to transform the Red Planet. I define four phases, which I term "exploration," "base building," "settlement," and "terraforming."

Exploration:

The exploration phase of Mars colonization has been going on for some time now with the telescopic and robotic surveys that have been and continue to be made. It will take a quantum leap, however, when actual human expeditions to the planet's surface begin. As I and others have shown in numerous papers^{1,2,3}, if the Martian atmosphere is exploited for the purpose of manufacturing rocket fuel and oxygen, the mass, complexity, and overall logistics requirements of such missions can be reduced to the point where affordable human missions to Mars can be launched with present day technology. Moreover, by using such "Mars Direct" type approaches, human explorers can be on Mars within 10 years of program initiation, with total expenditure not more than 20% of NASA's existing budget.

The purpose of the exploration phase is to resolve the major outstanding scientific questions bearing on the history of Mars as a planet and a possible home for life in the past, to conduct a preliminary survey of the resources of Mars and determine optimum locations for future human bases and settlements, and to establish a modus operandi whereby humans can travel to, reside on, and conduct useful operations over substantial regions of the surface of Mars.

Base Building:

The essence of the base building phase is to conduct agricultural, industrial, chemical, and civil engineering research on Mars as to master an increasing array of techniques required to turn Martian raw materials into useful resources. While properly conducted initial exploration missions will make use of the Martian air to provide fuel and oxygen, in the base building phase this elementary level of local resource utilization will be transcended as the crew of a permanent Mars base learns how to extract native water and grow crops on Mars, to produce ceramics, glasses, metals, plastics, wires, habitats, inflatable structures, solar panels, and all sorts of other useful materials, tools, and structures. While the initial exploration phase can be accomplished with small crews (of about 4 members each) operating out of Spartan base camps spread over vast areas of the Martian surface, the base building phase will require a division of labor entailing a larger number of people (on the order of 50), equipped with a wide variety of equipment and substantial sources of power. In short, the purpose of the base building period is to develop a mastery of those techniques required to produce on Mars the food clothing and shelter required to support a large population on the Red Planet.

The base building phase could begin in earnest about 10 years after the initial human landing on Mars.

Settlement:

Once the techniques have been mastered that will allow the support of a large population on Mars out of indigenous resources, the settlement of Mars can begin. The primary purpose of this phase is simply to populate Mars, creating a new branch of human civilization there with exponentially growing capabilities to transform the Red Planet.

While the Exploration and Base building phases can and probably must be carried out on the basis of outright government funding, during the Settlement phase economics comes to the fore. That is, while a Mars base of even a few hundred people can potentially be supported out of pocket by governmental expenditures, a Martian society of hundreds of thousands clearly cannot be. To be viable, a real Martian civilization must be either completely autarchic (very unlikely until the far future) or be able to produce some kind of export that allows it to pay for the imports it requires.

Terraforming:

If a viable Martian civilization can be established, its population and powers to change its planet will continue to grow. The advantages accruing to such a society of terraforming Mars into a more human-friendly environment are manifest⁴. Put simply, if enough people find a way to live and prosper on Mars there is no doubt but that sooner or later they will terraform the planet. The feasibility or lack thereof of terraforming Mars is thus in a sense a corollary to the economic viability of the Martian colonization effort.

Potential methods of terraforming Mars have been discussed in a number of locations.^{5,6}. In the primary scenario, artificial greenhouse gases such as halocarbons are produced on Mars and released into the atmosphere. The temperature rise induced by the presence of these gases causes CO₂ adsorbed in the regolith to be outgassed, increasing the greenhouse effect still more, causing more outgassing, etc. In reference 6 it was shown that a rate of halocarbon production of about 1000 tonnes per hour would directly induce a temperature rise of about 10 K on Mars, and that the outgassing of CO₂ caused by this direct forcing would likely raise the average temperature on Mars by 40 to 50 K, resulting in a Mars with a surface pressure over 200 mbar and seasonal incidence of liquid water in the warmest parts of the planet. Production of halocarbons at this rate would require an industrial establishment on Mars wielding about 5000 MW or power supported by a division of labor requiring at least (assuming optimistic application of robotics) 10,000 people. Such an operation would be enormous compared to our current space efforts, but very small compared to the overall human economic effort even at present. It is therefore anticipated that such efforts could commence as early as the mid 21st Century, with a substantial amount of the outgassing following on a time scale of a few decades. While humans could not breath the atmosphere of such a Mars, plants could, and under such conditions increasingly complex types of pioneering vegetation could be disseminated to create soil, oxygen, and ultimately the foundation for a thriving ecosphere on Mars. The presence of substantial pressure, even of an unbreathable atmosphere, would greatly benefit human settlers as only simple breathing gear and warm clothes (i.e. no spacesuits) would be required to operate in the open, and city-sized inflatable structures could be erected (since there would be no pressure differential with the outside world) that could house very large settlements in an open-air shirt-sleeve environment.

Nevertheless, Mars will not be considered fully terraformed until its air is breathable by humans. Assuming complete coverage of the planet with photosynthetic plants, it would take about a millennia to put the 120 mbar of oxygen in Mars' atmosphere needed to

support human respiration in the open. It is therefore anticipated that human terraformers would accelerate the oxygenation process by artificial technological approaches yet to be determined, with the two leading concepts being those based on either macroengineering (i.e. direct employment of very large scale energy systems such as terrawatt sized fusion reactors, huge space-based reflectors or lasers, etc.) or self reproducing machines, such as Turing machines or nanotechnology. Since such systems are well outside current engineering knowledge it is difficult to provide any useful estimate of how quickly they could complete the terraforming job. However in the case of self-replicating machines the ultimate source of power would be solar, and this provides the basis for an upper bound to system performance. Assuming the whole planet is covered with machines converting sunlight to electricity at 30% efficiency, and all this energy is applied to releasing oxygen from metallic oxides, a 120 mbar oxygen atmosphere could be created in about 30 years.

The Uniqueness of Mars

Among extraterrestrial bodies in our solar system, Mars is unique in that it possesses all the raw materials required to support not only life, but a new branch of human civilization. This uniqueness is illustrated most clearly if we contrast Mars with the Earth's Moon, the most frequently cited alternative location for extraterrestrial human colonization.

In contrast to the Moon, Mars is rich in carbon, nitrogen, hydrogen and oxygen, all in biologically readily accessible forms such as CO₂ gas, nitrogen gas, and water ice and permafrost. Carbon, nitrogen, and hydrogen are only present on the Moon in parts per million quantities, much like gold in sea water. Oxygen is abundant on the Moon, but only in tightly bound oxides such as SiO₂, Fe₂O₃, MgO, and Al₂O₃, which require very high energy processes to reduce. Current knowledge indicates that if Mars were smooth and all its ice and permafrost melted into liquid water, the entire planet would be covered with an ocean over 100 meters deep. This contrasts strongly with the Moon, which is so dry that if concrete were found there, Lunar colonists would mine it to get the water out. Thus, if plants were grown in greenhouses on the Moon (a very difficult proposition, as we shall see) most of their biomass material would have to be imported.

The Moon is also deficient in about half the metals (for example copper) of interest to industrial society, as well as many other elements of interest such as sulfur and phosphorus. Mars has every required element in abundance. Moreover, on Mars, as on Earth, hydrologic and volcanic processes have occurred, which is likely to have concentrated various elements into local concentrations of high-grade mineral ore. Indeed, the geologic history of Mars has been compared with that of Africa⁷, with very optimistic inferences as to its mineral wealth implied as a corollary. In contrast, the Moon has had virtually no history of water or volcanic action, with the result that it is basically composed of trash rocks with very little differentiation into ores that represent useful concentrations of anything interesting.

But the biggest problem with the Moon, as with all other airless planetary bodies and proposed artificial free-space colonies (such as those proposed by Gerard O'Neill⁸) is that sunlight is not available in a form useful for growing crops. This is an extremely important point and it is not well understood. Plants require an enormous amount of energy for their growth, and it can only come from sunlight. For example a single square kilometer of cropland on Earth is illuminated with about 1000 MW of sunlight at noon; a power load equal to an American city of 1 million people. Put another way, the amount of power required to generate the sunlight falling on the tiny country of El Salvador exceeds the combined capacity of every power plant on Earth. Plants can stand a drop of perhaps a factor of 5 in their light intake compared to terrestrial norms and still grow, but the fact

remains; the energetics of plant growth make it inconceivable to raise crops on any kind of meaningful scale with artificially generated light. That said, the problem with using the natural sunlight available on the Moon or in space is that it is unshielded by any atmosphere. (The Moon has an additional problem with its 28 day light/dark cycle, which is also unacceptable to plants). Thus plants grown in a thin walled greenhouse on the surface of the Moon or an asteroid would be killed by solar flares. In order to grow plants safely in such an environment, the walls of the greenhouse would have to be made of glass 10 cm thick, a construction requirement that would make the development of significant agricultural areas prohibitively expensive. Use of reflectors and other light-channeling devices would not solve this problem, as the reflector areas would have to be enormous, essentially equal in area to the crop domains, creating preposterous engineering problems if any significant acreage is to be illuminated.

Mars, on the other hand, has an atmosphere of sufficient density to protect crops grown on the surface against solar flares. On Mars, even during the base building phase, large inflatable greenhouses made of transparent plastic protected by thin hard-plastic ultra-violet and abrasion resistant geodesic domes could be readily deployed, rapidly creating large domains for crop growth. Even without the problems of solar flares and a month-long diurnal cycle, such simple greenhouses would be impractical on the Moon as they would create unbearably high temperatures. On Mars, in contrast, the strong greenhouse effect created by such domes would be precisely what is necessary to produce a temperate climate inside. Even during the base building phase, domes of this type up to 50 meters in diameter could be deployed on Mars that could contain the 5 psi atmosphere necessary to support humans. If made of high strength plastics such as Kevlar, such a dome could have a safety factor of 4 against burst and weigh only about 4 tonnes, with another 4 tonnes required for its unpressurized Plexiglas shield. In the early years of settlement, such domes could be imported pre-fabricated from Earth. Later on they could be manufactured on Mars, along with larger domes (with the mass of the pressurized dome increasing as the cube of its radius, and the mass of the unpressurized shield dome increasing as the square of the radius: 100 meter domes would mass 32 tonnes and need a 16 tonne Plexiglas shield, etc.). Networks of such 50 to 100 meter domes could rapidly be manufactured and deployed, opening up large areas of the surface to both shirtsleeve human habitation and agriculture. If agriculture only areas are desired, the domes could be made much bigger, as plants do not require more than about 1 psi atmospheric pressure. Once Mars has been partially terraformed however, with the creation of a thicker CO₂ atmosphere via regolith outgassing, the habitation domes could be made virtually to any size, as they would not have to sustain a pressure differential between their interior and exterior.

The point, however, is that in contrast to colonists on any other known extraterrestrial body, Martian colonists will be able to live on the surface, not in tunnels, and move about freely and grow crops in the light of day. Mars is a place where humans can live and multiply to large numbers, supporting themselves with products of every description made out of indigenous materials. Mars is thus a place where an actual civilization, not just a mining or scientific outpost, can be developed. And significantly for interplanetary commerce, Mars and Earth are the only two locations in the solar system where humans will be able to grow crops for export.

Interplanetary Commerce

Mars is the best target for colonization in the solar system because it has by far the greatest potential for self-sufficiency. Nevertheless, even with optimistic extrapolation of robotic manufacturing techniques, Mars will not have the division of labor required to make it fully self-sufficient until its population numbers in the millions. It will thus for a long time be

necessary, and forever desirable, for Mars to be able to pay for import of specialized manufactured goods from Earth. These goods can be fairly limited in mass, as only small portions (by weight) of even very high-tech goods are actually complex. Nevertheless, these smaller sophisticated items will have to be paid for, and their cost will be greatly increased by the high costs of Earth-launch and interplanetary transport. What can Mars possibly export back to Earth in return?

It is this question that has caused many to deem Mars colonization intractable, or at least inferior in prospect to the Moon. After all, the Moon does have indigenous supplies of helium-3, an isotope not found on Earth and which could be of considerable value as a fuel for thermonuclear fusion reactors. Mars has no known helium-3 resources. Because of its complex geologic history, Mars may have concentrated mineral ores, with much greater concentrations of ores of precious metals readily available than is currently the case on Earth due to the fact that the terrestrial ores have been heavily scavenged by humans for the past 5000 years. It has been shown⁹ that if concentrated supplies of metals of equal or greater value than silver (i.e. silver, germanium, hafnium, lanthanum, cerium, rhenium, samarium, gallium, gadolinium, gold, palladium, iridium, rubidium, platinum, rhodium, europium, etc.) were available on Mars, they could potentially be transported back to Earth at high profit by using reusable Mars-surface based single stage to orbit vehicles to deliver the cargoes to Mars orbit, and then transporting them back to Earth using either cheap expendable chemical stages manufactured on Mars or reusable cycling solar sail powered interplanetary spacecraft. The existence of such Martian precious metal ores, however, is still hypothetical.

Another alternative is that Mars could pay for itself by transporting back ideas. Just as the labor shortage prevalent in colonial and 19th century America drove the creation of Yankee Ingenuity's flood of inventions, so the conditions of extreme labor shortage combined with a technological culture and the unacceptability of impractical legislative constraints against innovation will tend to drive Martian ingenuity to produce wave after wave of invention in energy production, automation and robotics, biotechnology, and other areas. These inventions, licensed on Earth, could finance Mars even as they revolutionize and advance terrestrial living standards as forcefully as 19th Century American invention changed Europe and ultimately the rest of the world as well.

Inventions produced as a matter of necessity by a practical intellectual culture stressed by frontier conditions can make Mars rich, but invention is not the only way that Martians will be able to make a fortune. The other way is trade.

To understand this, it is necessary to consider the energy relationships between the Earth, Moon, Mars, and the main asteroid belt. The asteroid belt enters into the picture here because it is known to contain vast supplies of very high grade metal ore¹⁰ in a low gravity environment that makes it comparatively easy to export to Earth. Miners operating in the main belt, for reasons given above, will be unable to produce their necessary supplies locally. There will thus be a need to export food and other necessary goods from either Earth or Mars to the main belt. As shown in the table below, Mars has an overwhelming positional advantage as a location from which to conduct such trade.

Table 1 Transportation in the Inner Solar System

| | <u>Earth</u> | | <u>Mars</u> | |
|-----------------------------|--------------|------------|-------------|------------|
| | V(km/s) | Mass Ratio | V (km/s) | Mass Ratio |
| Surface to Low Orbit | 9.0 | 11.4 | 4.0 | 2.9 |
| Surface to Escape | 12.0 | 25.6 | 5.5 | 4.4 |
| Low Orbit to Lunar surface | 6.0 | 5.1 | 5.4 | 4.3 |
| Surface to Lunar Surface | 15.0 | 57.6 | 9.4 | 12.5 |
| Low Orbit to Ceres | 9.6 | 13.4 | 4.9 | 3.8 |
| Surface to Ceres | 18.6 | 152.5 | 8.9 | 11.1 |
| Ceres to Planet | 4.8 | 3.7 | 2.7 | 2.1 |
| NEP round-trip LO to Ceres | 40.0 | 2.3 | 15.0 | 1.35 |
| Chem to LO, NEP rt to Ceres | 9/40 | 26.2 | 4/15 | 3.9 |

In Table 1 all the entries except the last two are based upon a transportation system using CH_4/O_2 engines with an Isp of 380s and high thrust V 's. These were chosen because CH_4/O_2 is the highest performing space-storable chemical propellant, and can be manufactured easily on either Earth, Mars, or a carbonaceous asteroid. H_2/O_2 , while offering a higher Isp (450 s) is not storable for long duration's in space. Moreover, it is an unsuitable propellant for a cheap reusable space transportation system, since it costs more than an order of magnitude more than CH_4/O_2 (thus ruling it out for true cheap surface to orbit systems) and its bulk makes it very difficult to transport to orbit in any quantity using SSTO type vehicles. The last two entries in the table are based upon nuclear electric propulsion (NEP) using argon propellant, available at either the Earth or Mars, with an Isp of 5000 s for in-space propulsion, with CH_4/O_2 used to reach low orbit (LO) from the planet's surface.

It can be seen that if chemical systems are used exclusively, then the mass ratio required to deliver dry mass to the asteroid belt from Earth is 14 times greater than from Mars. This implies a still (much) greater ratio of payload to takeoff mass ratio from Mars to Ceres than from Earth because all the extra propellant requires massive tankage and larger caliber engines, all of which requires still more propellant, and therefore more tankage, etc. In fact, looking at Table 1 it can safely be said that useful trade between Earth and Ceres (or any other body in the Main asteroid belt) using chemical propulsion is probably impossible while from Mars it is easy. It can also be seen that there is a five-fold advantage in mass ratio delivering cargoes to the Earth's Moon from Mars over doing it from Earth.

If nuclear electric propulsion is introduced the story changes, but not much. Mars still has a 7-fold advantage in mass ratio over Earth as a port of departure for the Main Asteroid Belt, which translates into a payload to takeoff weight ratio nearly two orders of magnitude higher for Mars departure than for Earth.

A comparison of Earth to Ceres and Mars to Ceres all chemical and chemical/NEP missions is shown in Table 2. Both missions deliver 50 tonnes of cargo. Tankage for both NEP and chemical systems is calculated at 7% of the mass of the propellant required. For surface to orbit vehicles, it is assumed that dry mass excluding tankage is equal to the payload. For chemical interplanetary systems, it is assumed that the dry inert mass excluding tankage is equal to 20% the payload. The NEP versions in Table 2 are 10 MWe for delivery from Mars and 30 MWe for delivery from Earth, with each NEP system massing 5 tonnes/MW. The different power ratings give both systems about equal power/mass ratios; the system leaving Earth still burns 2.4 times as long. If it were desired to increase the power rating of

the Earth-based NEP vessel so that its burn time were the same as the Mars-based system, the mass of the Earth-based mission would go to infinity. In Table 2 the mass numbers are for the total mission, it is understood that the total launch requirement could be divided up into many launch vehicles, as required.

Table 2. Mass of Freighter missions to the Main Asteroid Belt (tonnes)

| Planet of Departure | Earth | | Mars | |
|----------------------------|---------------------------------|----------|---------------------------------|----------|
| | CH ₄ /O ₂ | Chem/NEP | CH ₄ /O ₂ | Chem/NEP |
| Propulsion system | | | | |
| Payload | 50 | 50 | 50 | 50 |
| Interplanetary Spacecraft | 10 | 150 | 10 | 50 |
| Interplanetary Tankage | 85 | 19 | 15 | 3 |
| Interplanetary Propellant | 1220 | 268 | 205 | 37 |
| Total Mass in Low Orbit | 1365 | 487 | 280 | 140 |
| Launch Vehicle Inert Mass | 1365 | 337 | 280 | 90 |
| Launch Vehicle Tankage | 6790 | 1758 | 88 | 28 |
| Launch Vehicle Propellant | 97000 | 25127 | 1250 | 401 |
| Total Ground Lift Off Mass | 106520 | 27559 | 1898 | 609 |

It can be seen that the launch burden for sending the cargo to Ceres is about 50 times less for missions starting from Mars than those departing from Earth, regardless of whether the technology employed is all chemical propulsion or chemical launch vehicles combined with nuclear electric propulsion for interplanetary transfer. If the launch vehicle used has a 1000 tonne liftoff mass, it would require 107 launches to assemble the CH₄/O₂ freighter mission if launched from Earth, but only 2 launches if the departure is from Mars. Even if propellant and other launch costs were ten times greater on Mars than on Earth, it would still be enormously advantageous to launch from Mars.

The result that follows is simply this: anything that needs to be sent to the asteroid belt that can be produced on Mars will be produced on Mars.

The outline of future interplanetary commerce thus becomes clear. There will be a “triangle trade,” with Earth supplying high technology manufactured goods to Mars, Mars supplying low technology manufactured goods and food staples to the asteroid belt and possibly the Moon as well, and the asteroids and Moon sending metals and possibly helium-3 to Earth. This triangle trade, illustrated in Fig. 1 is directly analogous to the triangle trade of Britain, her North American colonies, and the West Indies during the colonial period. Britain would send manufactured goods to North America, the American colonies would send food staples and needed craft products to the West Indies, and the West Indies would send cash crops such as sugar to Britain. A similar triangle trade involving Britain, Australia, and the Spice Islands also supported British trade in the East Indies during the 19th Century.

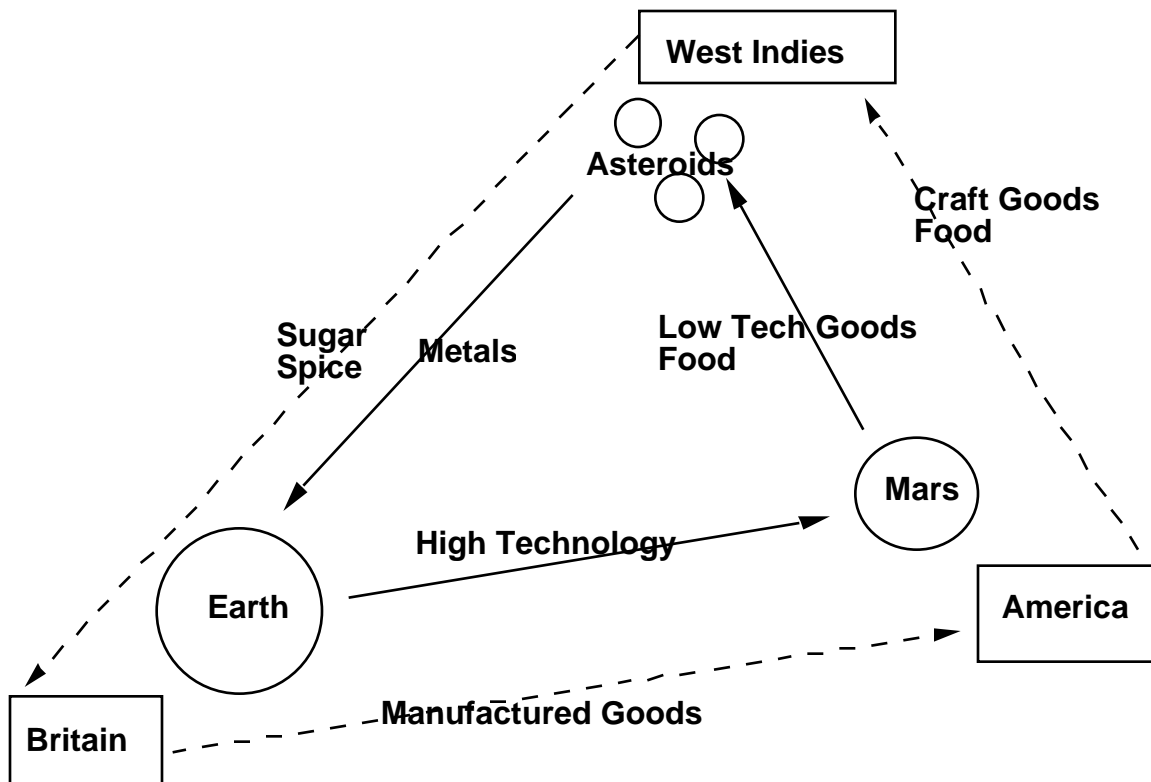

Fig. 1 The triangle trade: 18th Century and 21st Century.

Populating Mars

"This proposition being made publike and coming to the scanning of all, it raised many variable opinions amongst men, and caused many fears & doubts amongst themselves. Some, from their reasons & hops conceived, laboured to stirr up & incourage the rest to undertake and prosecute the same; others, againe, out of their fears, objected against it, & sought to diverte from it, aleding many things, and those neither unreasonable nor unprobable; as that it was a great designe, and subjecte to many unconceivable perills & dangers...

"It was answered that all great & honourable actions are accompanied with great difficulties, and must be both enterprised and overcome with answerable courages."

-Gov. William Bradford, "Of Plimoth Plantation," 1621.

The difficulty of interplanetary travel may make Mars colonization seem visionary. However colonization is, by definition, a one way trip, and it is this fact which makes it possible to transport the large numbers of people that a colony in a new world needs to succeed.

Let us consider two models of how humans might emigrate to Mars; a government sponsored model and a privately sponsored model.

If government sponsorship is available, the technological means required for immigration on a significant scale are essentially available today. In fig. 2 we see one version of such a concept that could be used to transport immigrants to Mars. An Shuttle derived heavy lift launch vehicle lifts 145 tonnes (A Saturn V had about this same capacity) to low Earth orbit, then a nuclear thermal rocket (NTR, such as was demonstrated in the USA in the 1960's) stage with an Isp of 900 s hurls a 70 tonne "habcraft" onto a 7 month trajectory to Mars. Arriving at Mars, the habcraft uses its biconic shell to aerobrake, and then parachutes and lands on its own sets of methane/oxygen engines.

The habcraft is 8 meters in diameter and includes four complete habitation decks, for a total living area of 200 m², allowing it to adequately house 24 people in space and on Mars. Expansion area is available in the fifth (uppermost) deck after the cargo it contains is unloaded upon arrival.

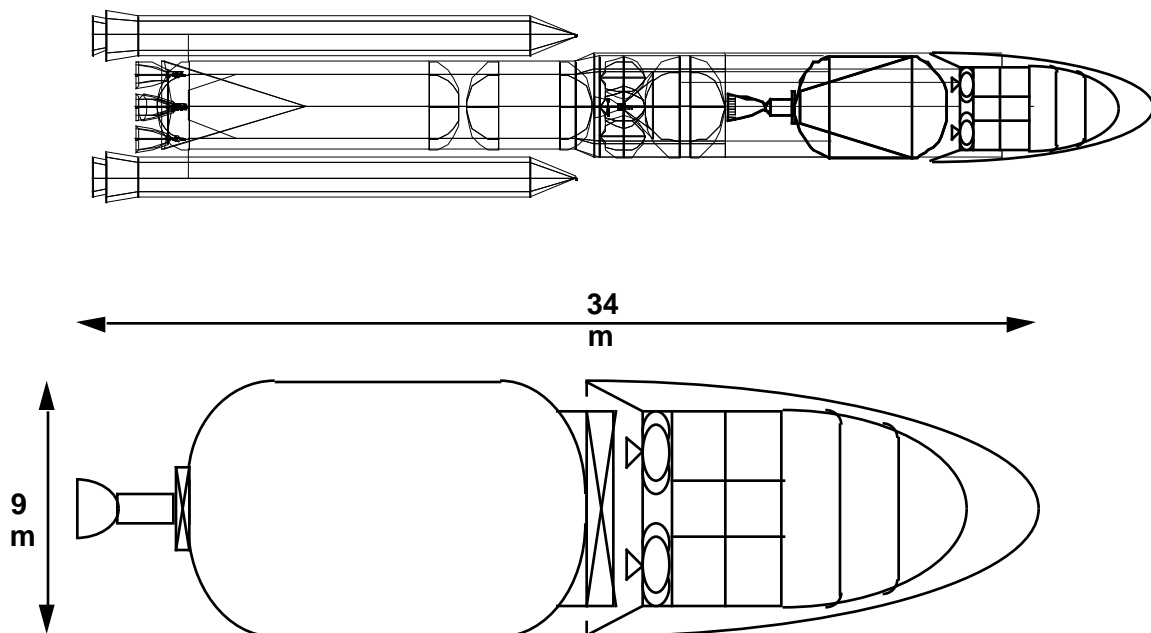

Fig. 2. An NTR augmented heavy lift launch vehicle, capable of transporting 24 colonists 1-way to the Red Planet.

Thus in a single booster launch, 24 people, complete with their housing and tools, can be transported one way from Earth to Mars.

Now let us assume that starting in 2030 AD, an average of four such boosters are launched every year from Earth. If we then make various reasonable demographic assumptions, the population curve for Mars can be computed. The results are shown in fig. 3. Examining the graph, we see that with this level of effort (and the technology frozen at late 20th Century levels forever), the rate of human population growth of Mars in the 21st Century would be about 1/5th that experienced by colonial America in the 17th and 18th Centuries.

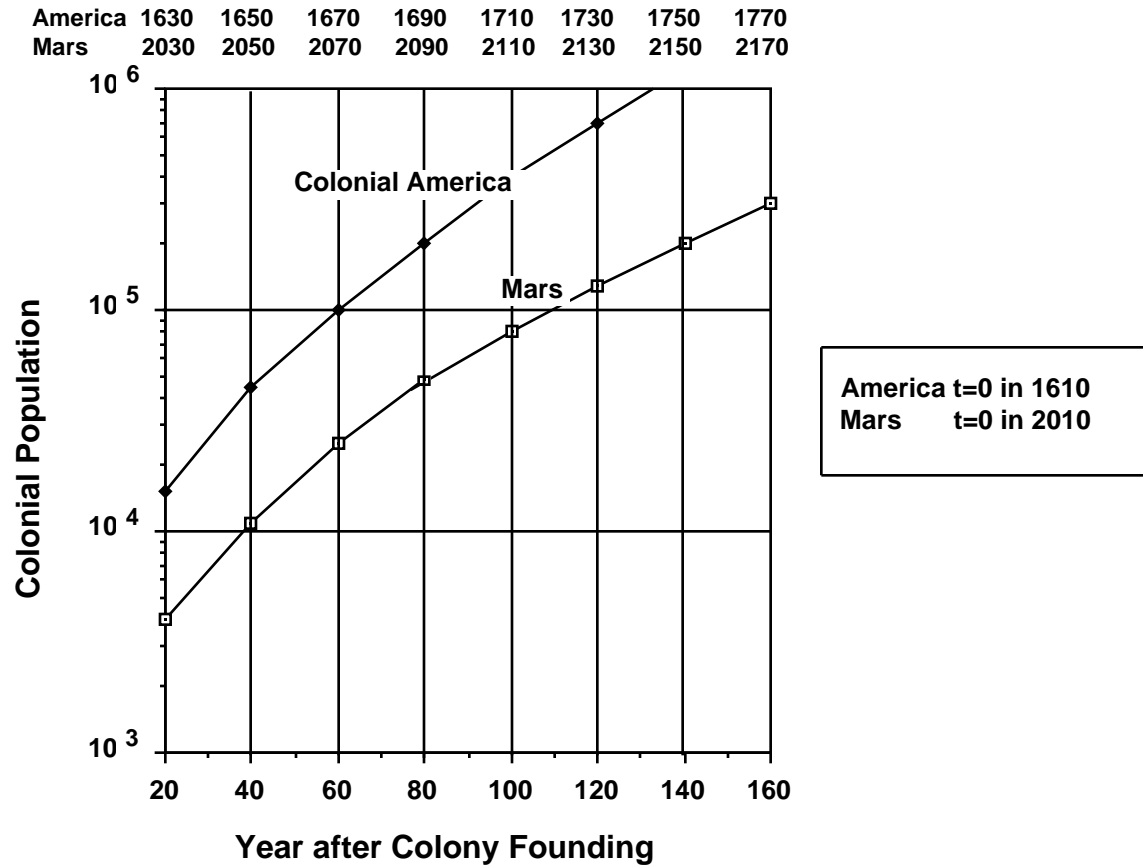

Fig. 3. Colonization of Mars compared to North America. Analysis assumes 100 immigrants/year starting in 2030, increasing at 2% annual rate, 50/50 male/female. All immigrants are between ages 20 and 40. Average of 3.5 children to an ideal Martian family. Mortality rates are 0.1% per year between ages 0 and 59, 1% between ages 60 and 79, 10% per year for those over 80.

This in itself is a very significant result. What it means is that the distance to Mars and the transportation challenge that it implies is not a major obstacle to the initiation of a human civilization on the Red Planet. Rather the key questions become those of resource utilization, growing food, building housing, and manufacturing all sorts of useful goods on the surface of Mars. Moreover the projected population growth rate, 1/5th that of Colonial America, while a bit slow, is significant on a historical scale, and assuming a cost of \$1 billion per launch, the \$4 billion per year program cost could be sustained for some time by any major power on Earth that cared to plant the seeds of its posterity on Mars.

However, with a cost per launch of about \$1 billion, the cost per immigrant would be \$40 million. Such a price might be affordable to governments (for a time), but not to individuals or private groups. If Mars is ever to benefit from the dynamic energy of large numbers of immigrants motivated by personal choice to seek to make their mark in a new world, the transportation fee will have to drop a lot lower than this. Let us therefore examine an alternative model to see how low it is likely to drop.

Consider once again out CH₄/O₂ SSTO vehicles used to transport payloads from the surface of the Earth to low Earth orbit. For every kilogram of payload delivered to orbit,

about 70 kilograms of propellant are required. CH₄/O₂ bipropellant costs about \$0.20/kilogram, so \$14 of propellant costs will be incurred for every kilogram lifted to orbit. If we then assume total system operation cost is 7 times propellant costs (roughly double the total cost/fuel cost ratio of airlines), then the cost of delivery to low Earth orbit (LEO) could be about \$100/kilogram. If we assume that there is operating between Earth and Mars a cycling spacecraft which has the ability to recycle water and oxygen with 95% efficiency, then each passenger (100 kg with personal effects) will have to bring about 400 kg of supplies to provide himself with food, water and oxygen during a 200 day outbound trip to Mars. Thus 500 kg will need to be transported through a ΔV of about 4.3 km/s to move the immigrant from LEO to a (2 year period) cycling interplanetary spacecraft. The capsule mass, used to transport the immigrant from LEO to the cyler and from the cyler to the Martian surface could be assumed optimistically to have a mass of 500 kg per passenger. Thus for each passenger a total of 1000 kg needs to be delivered to the cyler orbit, which with an Isp of 380 s for the CH₄/O₂ propulsion system on the transfer capsules translates into 3200 kg in LEO. At a delivery price of \$100/kg to LEO, and assuming that the cost of the cyler itself is amortized over a very large number of missions, this in turn translates into a cost of \$320,000 per passenger to Mars.

Obviously, there are many assumptions in the above calculation that could be changed that would either raise or lower the calculated ticket price significantly. For example use of air-breathing supersonic ramjet propulsion to perform a significant part of the Earth to orbit ΔV could cut orbit delivery costs by as much as a factor of 3. Using an electric propulsion LEO to L1 electric propulsion ferry followed by a powered flyby through a LEO perigee using high thrust chemical stage would allow the cyler to be reached with a chemical ΔV of only 1.3 km/s, thereby doubling payload and reducing costs yet again. If the cyler employs a magnetic sail¹¹ instead of simply using natural ballistic orbits with gravity assists, the hyperbolic velocity departing Earth required to rendezvous with it can be essentially zero, thereby allowing the entire LEO to cyler delivery to be done by electric propulsion, or conceivably even solar or magnetic sails. Increasing the degree of closure of the life support system on the cyler would reduce the consumable delivery requirement for each passenger, thereby reducing passage costs still more. Thus eventually Earth to Mars transportation costs could be expected to drop another order of magnitude, to \$30,000 per passenger or so. The costs impacts as each of these innovations is progressively introduced is displayed in Table 3.

Table 3. Possible Cost Reductions of Earth to Mars Transportation System

| | <u>Baseline</u> | <u>Advanced</u> | <u>Reduction Factor</u> | <u>Fare to Mars</u> |
|-----------------------|---------------------------------|-----------------|-------------------------|---------------------|
| Baseline Mission | ----- | ----- | 1.0 | \$320,000 |
| Earth to Orbit | Rockets | Scramjets | 0.3 | \$ 96,000 |
| Life Support Closure | 95% | 99% | 0.7 | \$ 67,000 |
| LEO Escape Propulsion | CH ₄ /O ₂ | NEP | 0.6 | \$ 40,000 |
| Cyler Propulsion | Natural | Magsail | 0.7 | \$ 28,000 |

Nevertheless, the order of magnitude of the \$320,000 fare cited for early immigrants-roughly the cost of a upper-middle class house in many parts of suburban America, or put another way, roughly the life's savings of a successful middle class family - is interesting. It's not a sum of money that anyone would spend lightly, but it is a sum of money that a large number of people could finance if they really wanted to do so. Why would they want to do so? Simply this, because of the small size of the Martian population and the large

transport cost itself, it is certain that the cost of labor on Mars will be much greater than on Earth. Therefore wages will be much higher on Mars than on Earth; while \$320,000 might be 6 year's salary to an engineer on Earth, it would likely represent only 1 or 2 years' salary on Mars. This wage differential, precisely analogous to the wage differential between Europe and America during most of the past 4 centuries, will make emigration to Mars both desirable and possible for the individual. From the 17th through 19th centuries the classic pattern was for a family in Europe to pool its resources to allow one of its members to emigrate to America. That emigrant, in turn, would proceed to earn enough money to bring the rest of the family over. Today, the same method of obtaining passage is used by Third World immigrants whose salaries in their native lands are dwarfed by current air-fares. Because the necessary income will be there to pay for the trip after it has been made, loans can even be taken out to finance the journey. It's been done in the past, it'll be done in the future.

As mentioned before, the labor shortage that will prevail on Mars will drive Martian civilization towards both technological and social advances. If you're paying five times the terrestrial wage rate you're not going to want to waste any of your worker's time with stoop labor or filling out forms, and you will not seek to exclude someone who can perform some desperately needed profession from doing so just because he or she has not taken the trouble to run some institutional obstacle course to obtain appropriate certifications. In short, Martian civilization will be practical because it will have to be, just as 19th Century American civilization was, and this forced pragmatism will give it an enormous advantage in competing with the less stressed, and therefore more tradition bound society remaining behind on Earth. Necessity is the mother of invention; Mars will provide the cradle. A frontier society based on technological excellence and pragmatism, and populated by people self-selected for personal drive, will perforce be a hot-bed of invention, and these inventions will not only serve the needs of the Martians but of the terrestrial population as well. Therefore they will bring income to Mars (via terrestrial licensing) at the same time they disrupt the labor-rich terrestrial society's inherent tendency towards stagnation. This process of rejuvenation, and not direct economic benefits via triangle-trade for main-belt asteroid mineral resources, will ultimately be the greatest benefit that the colonization of Mars will offer Earth, and it will be those terrestrial societies who have the closest social, cultural, linguistic, and economic links with the Martians who will benefit the most.

Selling Martian Real-Estate

Martian real-estate can be broken down into two categories; habitable and open. By habitable real-estate I mean that which is under a dome, allowing human settlers to live there in a relatively conventional shirt-sleeve open-air environment. Open real-estate is that which is outside the domes. It is obvious that habitable real-estate is far more valuable than open real-estate. Nevertheless, both of these can be bought and sold, and as transportation costs drop, both forms of Martian real-estate will rise in value.

The only kind of land that exists on Mars right now is open. There is an immense amount of it - 143 million square kilometers - but it might seem that that it is all completely worthless because it cannot currently be exploited. Not so. Enormous tracts of land were bought and sold in Kentucky for very large sums of money a hundred years before settlers arrived - for purposes of development trans-Appalachian America might as well have been Mars in the 1600's. What made it salable were two things: 1) That at least a few people believed that it would be exploitable someday, and 2) That a juridical arrangement existed (in the form of British Crown land patents) which allowed trans-Appalachian land to be privately owned. In fact, if a mechanism were put in place that could enforce private property rights on Mars, land on Mars could probably be bought and sold now. Such a

mechanism would not need to employ enforcers (e.g. space police) on the surface of Mars; the patent or property registry of a sufficiently powerful nation, such as the United States, would be entirely adequate. For example, if the United States chose to grant a mining patent to any private group that surveyed a piece of Martian real-estate to some specified degree of fidelity, such claims would be tradable today on the basis of their future speculative worth (and could probably be used to privately finance robotic mining survey probes in the near future). Furthermore, such claims would be enforceable internationally and throughout the solar system simply by having the US Customs Office penalize with a punitive tariff any US import made anywhere, directly or indirectly, with material that was extracted in defiance to the claim. This sort of mechanism would not imply US sovereignty over Mars, any more than the current US Patent and Copyright Offices coining of ideas into intellectual property implies US government sovereignty over the universe of ideas. But whether it's US, NATO, UN, or Martian Republic, some government's agreement is needed to turn worthless terrain into real-estate property value.

Once that is in place, however, even the undeveloped open real-estate on Mars represents a tremendous source of capital to finance the initial development of Martian settlements. Sold at an average value of \$10 per acre, Mars would be worth \$358 billion. If Mars should be terraformed, these open land prices could be expected to grow 100-fold, with a rough planetary land value of \$36 trillion implied. Assuming, as appears to be the case, that a method of terraforming Mars could be found with a total cost much less than this, then those who own Mars would have every reason to seek to develop their property via planetary engineering.

Of course, all open real-estate on Mars will not be of equal value; those sections known to contain valuable minerals or other resources, or which are located closer to the habitable areas will be worth much more. For these reasons, as with land speculators on Earth in the past, the owners of open unexplored real-estate on Mars will exercise all their influence to further the exploration of, and encourage the settlement of land under their control.

Far more valuable than the open real-estate will be habitable real estate beneath the domes. Each 100 meter diameter dome, massing about 50 tonnes (32 tonnes for the inflatable Kevlar pressure dome, 16 tonnes for the Plexiglas geodesic rigid shield dome, 2 tonnes for miscellaneous fittings), would enclose an area of about 2 acres. Assuming that dwelling units for 20 families are erected within it, and each family is willing to pay \$50,000 for their habitation land (a plot 20 meters on a side), then the total real-estate value enclosed by a single dome would be \$1,000,000. At this rate, the creation of habitable land by the mass production and erection of large numbers of domes to house the waves of immigrants should prove to be one of the biggest businesses on Mars and a major source of income for the colony.

In the 21st Century, Earth's population growth will make real-estate here ever more expensive, making it ever harder for people to own their own homes. At the same time, the ongoing bureaucratization of the former terrestrial frontier societies will make it ever harder for strong spirits to find adequate means for expressing their creative drive and initiative on Earth. Regulation to "protect" what is will become ever more burdensome to those who would create what is not. A confined world will limit opportunity for all and seek to enforce behavioral and cultural norms that will be unacceptable to many. When the frictions turn into inevitable revolts and wars, there will be losers. A planet of refuge will be needed, and Mars will be there.

Historical Analogies

"...to the frontier the American intellect owes its striking characteristics. That coarseness of strength combined with acuteness and inquisitiveness; that practical, inventive turn of mind, quick to find expedients; that masterful grasp of material things, lacking in the artistic but powerful to effect great ends; that restless, nervous energy; that dominant individualism, working for good and evil, and withal that buoyancy and exuberance that comes from freedom - these are the traits of the frontier, or traits called out elsewhere because of the existence of the frontier. Since the days when the fleets of Columbus sailed into the waters of the New World, America has been another name for opportunity, and the people of the United States have taken their tone from the incessant expansion which has not only been open but has even been forced upon them. ... at the frontier, the bonds of custom are broken and unrestraint is triumphant. ...and freshness, and confidence, and scorn of older society, impatience of its restraints and its ideas, and indifference to its lessons, have accompanied the frontier. What the Mediterranean Sea was to the Greeks, breaking the bonds of custom, offering new experiences, calling out new institutions and activities, that, and more, the ever retreating frontier has been to the United States directly, and to the nations of Europe more remotely. And now, four centuries from the discovery of America, at the end of a hundred years of life under the Constitution, the frontier has gone..."

- Frederick Jackson Turner, 1893

The primary analogy to be drawn is that Mars is to the new age of exploration as North America was to the last. The Earth's Moon, close to the metropolitan planet but impoverished in resources compares to Greenland. Other destinations, such as the Main Belt asteroids may be richer in potential future exports to Earth but lack the preconditions for the creation of a fully developed indigenous society; these compare to the West Indies. Only Mars has the full set of resources required to develop a native civilization, only Mars is a viable target for true colonization. Like America in its relationship to Britain and the West Indies, Mars has a positional advantage that will allow it to participate in a useful way to support extractive activities on behalf of Earth in the asteroid belt and elsewhere. but despite the short sighted calculations of 18th Century European statesmen and financiers, the true value of America never was as a logistical support base for West Indies sugar and spice trade, inland fur trade, or as a potential market for manufactured goods. The true value of America was as the future home for a new branch of human civilization, one which as a combined result of its humanistic antecedents and its frontier conditions was able to develop into the most powerful engine for human progress and economic growth the world had ever seen. The wealth of America was in the fact that she could support people, and that the right kind of people chose to go to her. People create wealth, people create power. People *are* wealth and power. Every feature of frontier American life that acted to create a practical can-do culture of innovating people will apply to Mars a hundred-fold.

Mars is a harsher place than any on Earth. But provided one can survive the regimen, it is the toughest schools that are the best. The Martians shall do well.

Conclusions

We have examined the prospects for colonizing Mars, addressing the question of its economic viability. We have shown, that of all bodies in the solar system other than Earth, Mars is unique in that it has the resources required to support a population of sufficient size to create a new branch of human civilization. We have seen that despite the fact that Mars

may lack any resource directly exportable to Earth, Mars' orbital elements and other physical parameters gives a unique positional advantage that will allow it to act as a keystone supporting extractive activities in the asteroid belt and elsewhere in the solar system. We have examined the potential of relatively near-term types of interplanetary transportation systems, and shown that with very modest advances on a historical scale, systems can be put in place that will allow individuals and families to emigrate to Mars at their own discretion. Their motives for doing so will parallel in many ways the historical motives for Europeans and others to come to America, including higher pay rates in a labor-short economy, escape from tradition and oppression, as well as freedom to exercise their drive to create in an untamed and undefined world. Under conditions of such large scale and open immigration, sale of real-estate will add a significant source of income to the planet's economy. However the greatest source of Martian wealth, and the greatest benefit of its existence to the terrestrial world, will be as a pressure cooker for invention and innovation of every type. In analogy to frontier America but going well beyond it, Mars will be a society of self-selected immigrants, operating in a harsh, labor-short environment in which practical innovation and technological acumen will be at a premium. Licensing on Earth of the inventions created under conditions of necessity on Mars will bring vast amounts of income to support the development of the Red Planet, even as these same inventions continue to raise terrestrial living standards and destabilize tendencies that would otherwise exist on Earth towards technological and social stagnation.

What the Mediterranean was to the Greeks, what the New World was to the Western Europeans, Mars will be to the pioneering nations of the next several centuries; the engine of progress of the coming era. As America showed in the 19th Century, such an engine of can pull far more than its own weight.

References

1. D. Baker and R. Zubrin, "Mars Direct: Combining Near-Term Technologies to Achieve a Two-Launch Manned Mars Mission," JBIS, Vol. 43 No. 11, Nov. 1990 pp. 519-526
2. R. Zubrin, "Mars and Luna Direct," Journal of Practical Applications in Space, Vol 4, No. 1, Fall 1992, pp 25-80
3. R. Zubrin and D. Weaver, "Practical Methods for Near-Term Piloted Mars Missions," AIAA 93-2089 AIAA/SAE 29th Joint Propulsion Conference, Monterey CA 1993, JBIS, June 1995
4. M. Fogg, "Advantages of Terraforming for the Human Settlement of Mars," Presented to the Case for Mars V, Boulder CO, June 1993
5. M. Fogg, "Terraforming" SAE 1995
6. R. Zubrin and C. McKay, "Technological Requirements for Terraforming Mars," AIAA 93-2005, AIAA/SAE 29th Joint Propulsion Conference, Monterey CA 1993.
7. B. Cordell, "A Preliminary Assessment of Martian Natural Resource Potential," AAS 84-185, presented to the Case for Mars II conference, Boulder, CO, July 1984.
8. G. O'Neill, "The High Frontier," William Morrow and Co. New York, 1977.

9. R. Zubrin and David Baker, "Mars Direct: Humans to the Red Planet by 1999" IAF-90-672, 41st Congress of the International Astronautical Federation, Dresden, Germany, Oct. 1990. *Acta Astronautica*

10. J. Lewis and R. Lewis, "Resources from Space: Breaking the Bonds of Earth"

11. R. Zubrin and D. Andrews, "Magnetic Sails and Interplanetary Travel," *Journal of Spacecraft and Rockets*, Vol 28, No. 2, pp 197-203, March-April 1991.